

## Concept Frames

2015 Industrial Drive, Newton, NC 28658  
PH: 888-234-9455 Fax: 800-631-9089  
[www.ConceptFrames.Com](http://www.ConceptFrames.Com)

Drawn By: KX

Date: 1-23-2015

5/8" Thick Fire Rated Panel

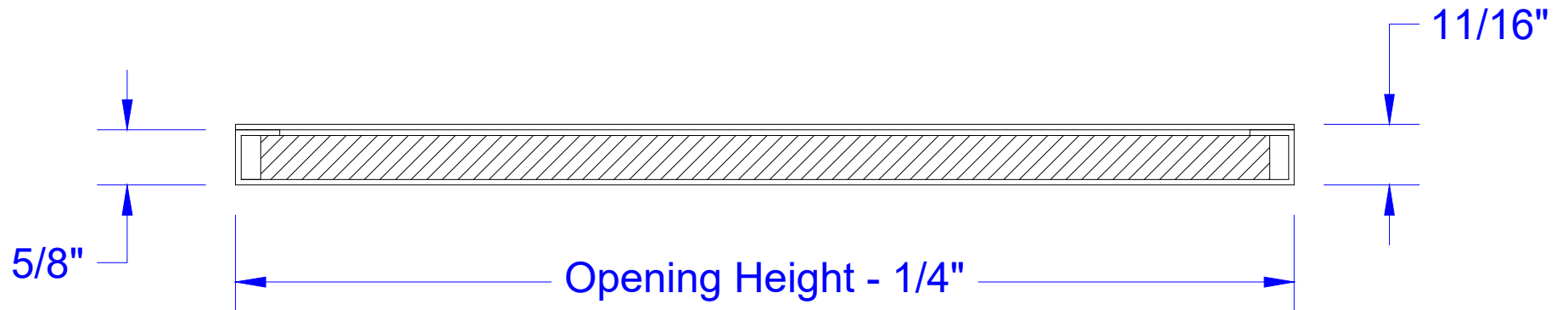
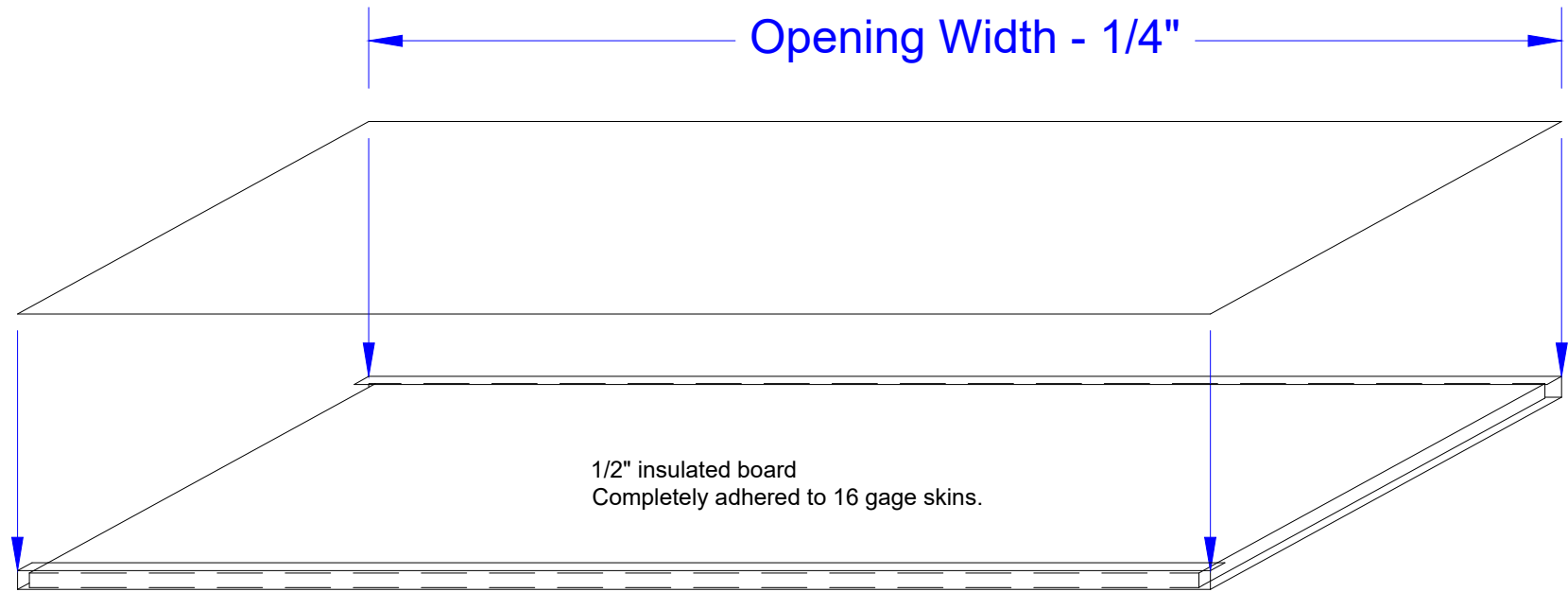

# Concept Frames

2015 Industrial Drive, Newton, NC 28658  
PH: 888-234-9455 Fax: 800-631-9089  
[www.ConceptFrames.Com](http://www.ConceptFrames.Com)

Drawn By: KX

Date: 1-23-2015

11/16" Thick Insulated Panel

# Top View

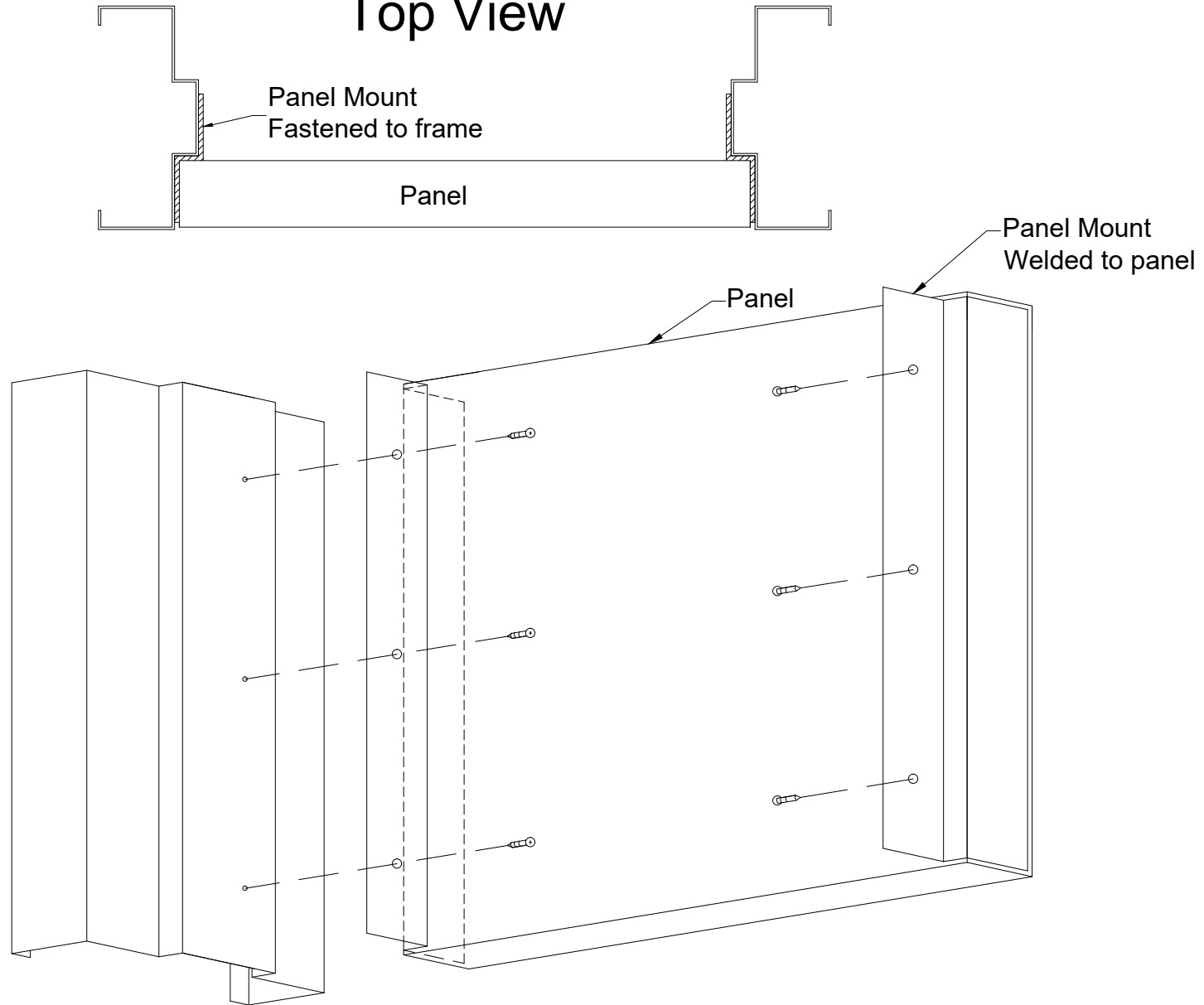

## Concept Frames

2015 Industrial Drive, Newton, NC 28658  
PH: 888-234-9455 Fax: 800-631-9089  
[www.ConceptFrames.Com](http://www.ConceptFrames.Com)

Drawn By: KX

Date: 1-23-2015

Removable Panel Mounts

Not to scale



## Concept Frames

2015 Industrial Drive, Newton, NC 28658  
PH: 888-234-9455 Fax: 800-631-9089

[www.ConceptFrames.Com](http://www.ConceptFrames.Com)

Drawn By: KX

Date: 1-23-2015

Sheet Metal Panel  
Installed in hollow metal frame